

TIPO DE MATERIAL	FACTOR DE ABRANDAMIENTO	FACTOR DE COMPACTACION	ORDENADAS DE LA CURVA MASA	VOLUMEN	ESPEZOR	ELEVACION
TERRAPLEN	1.00	0.90	10.000	0.00	0.00	43.35
CORTE	0.00	0.00	10.000	0.00	0.00	43.35
TERRAPLEN	1.00	0.90	10.000	0.00	0.00	43.35
CORTE	0.00	0.00	10.000	0.00	0.00	43.35
SUBRASANTE	1.00	0.90	10.000	0.00	0.00	43.35
TERRENO	1.00	0.90	10.000	0.00	0.00	43.35

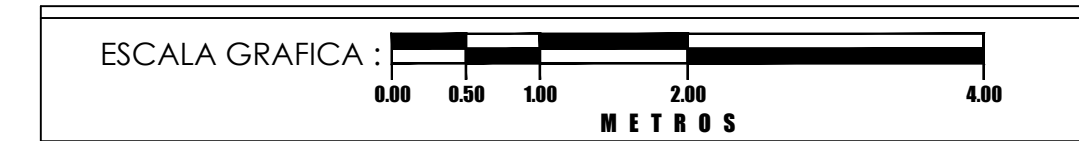

ESPECIFICACIONES GENERALES

CROQUIS DE LOCALIZACION

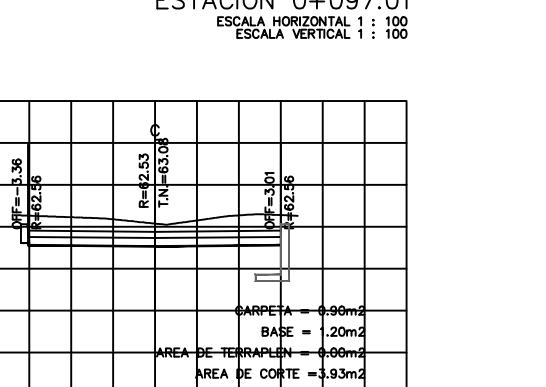
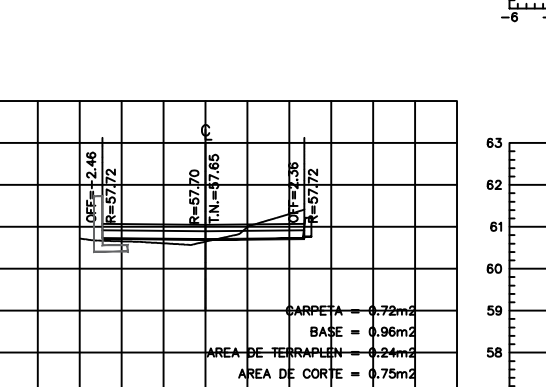
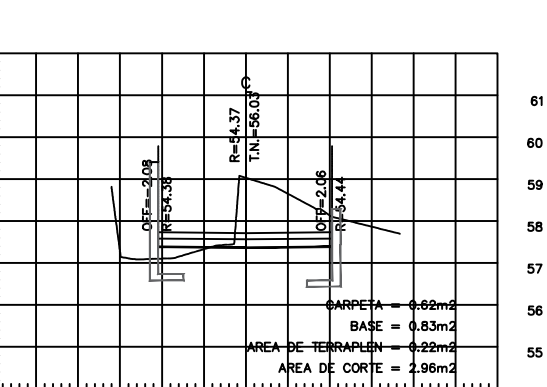
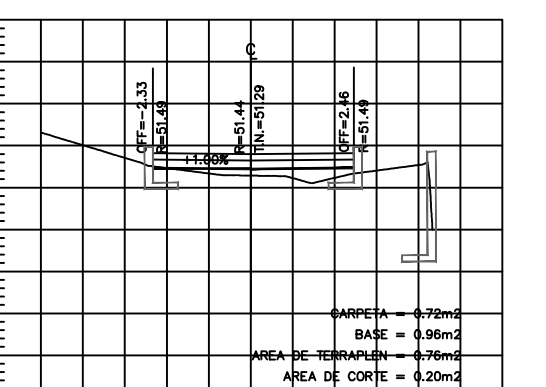
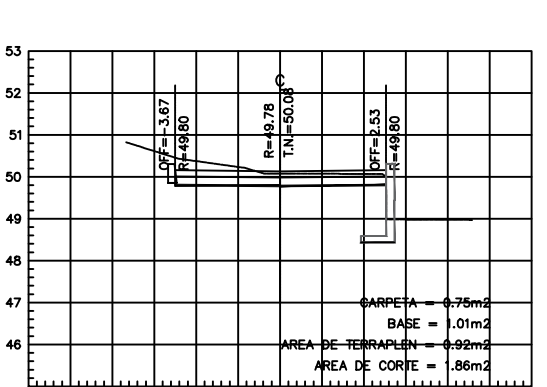
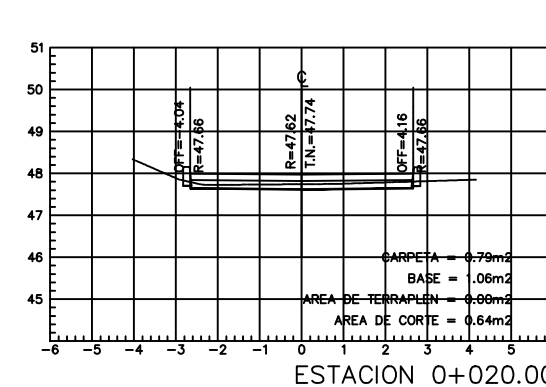
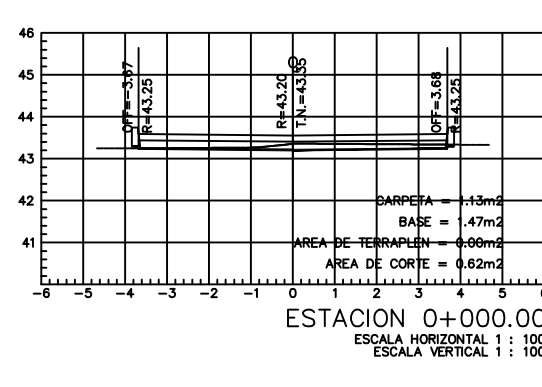
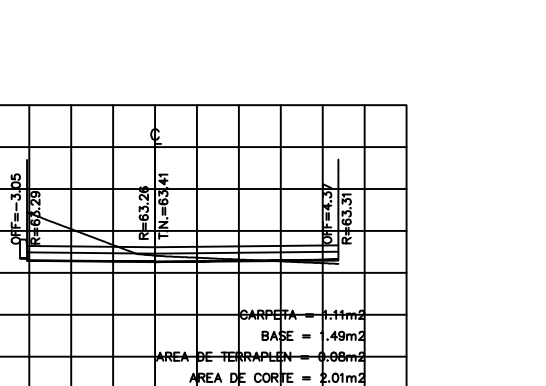
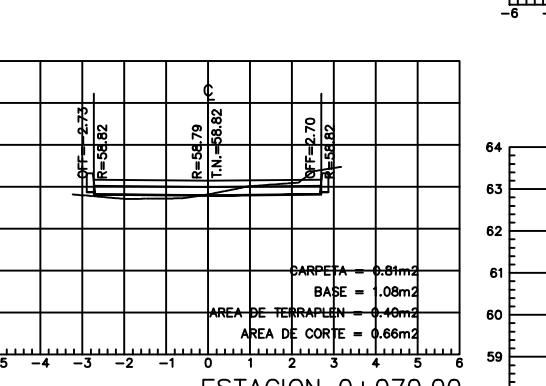
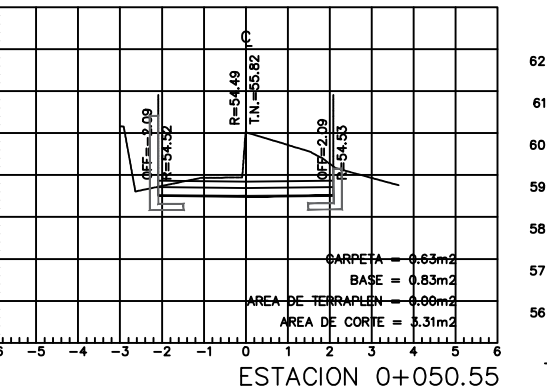
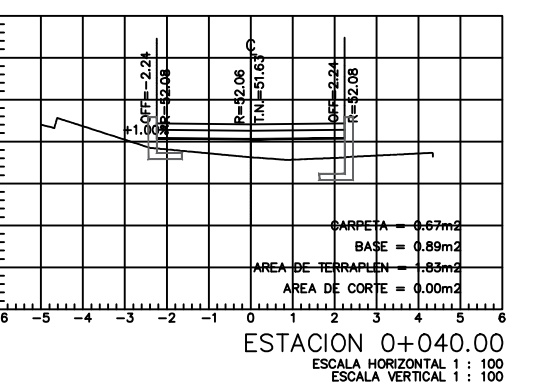
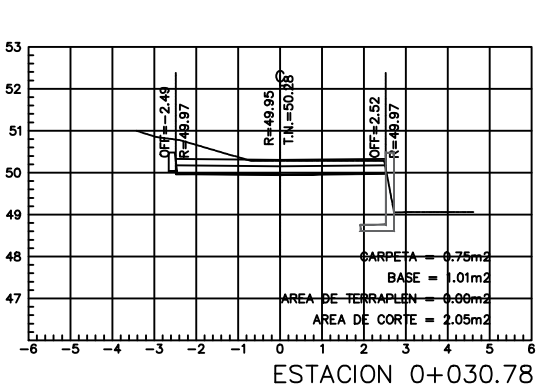
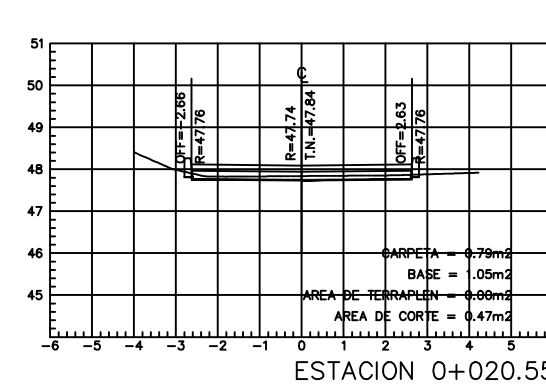
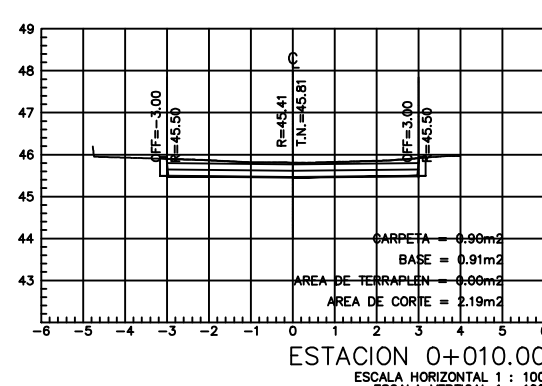
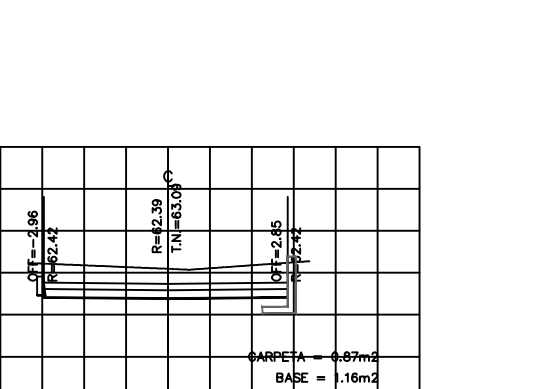
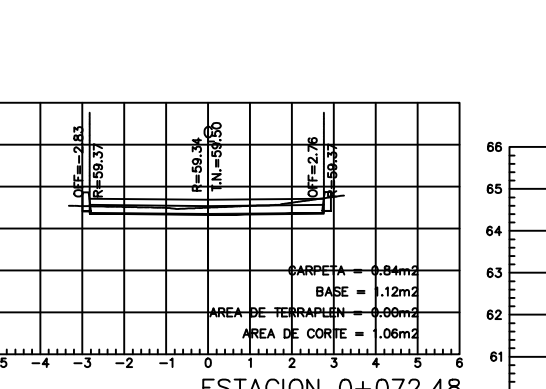
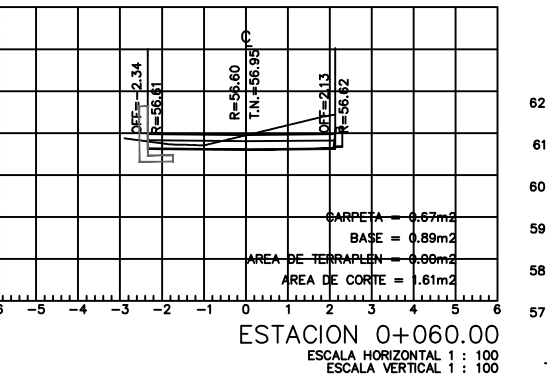
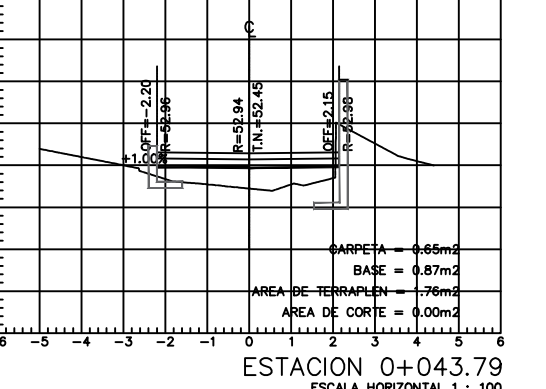
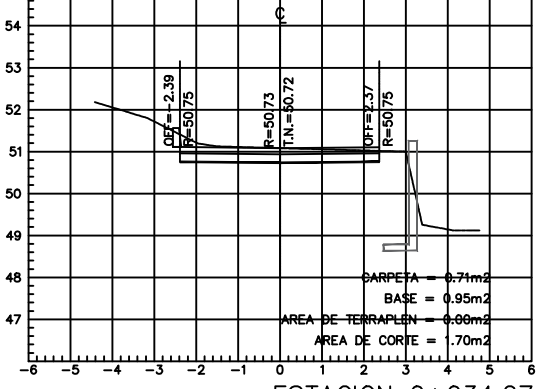
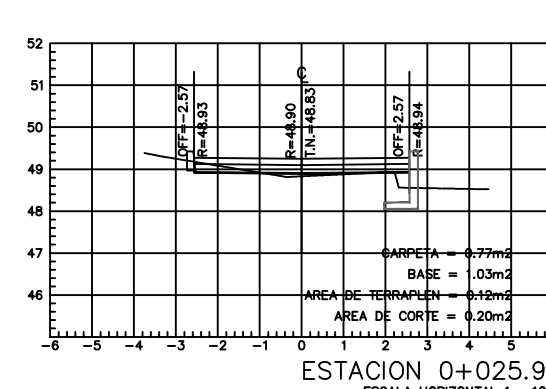
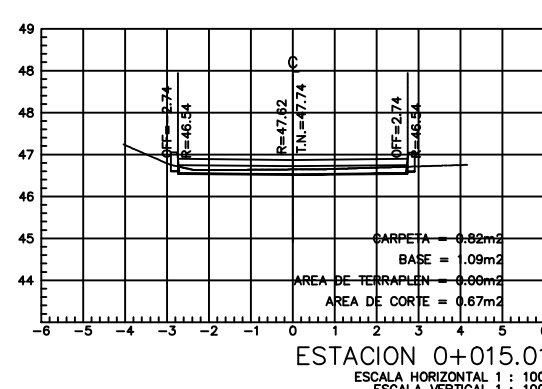
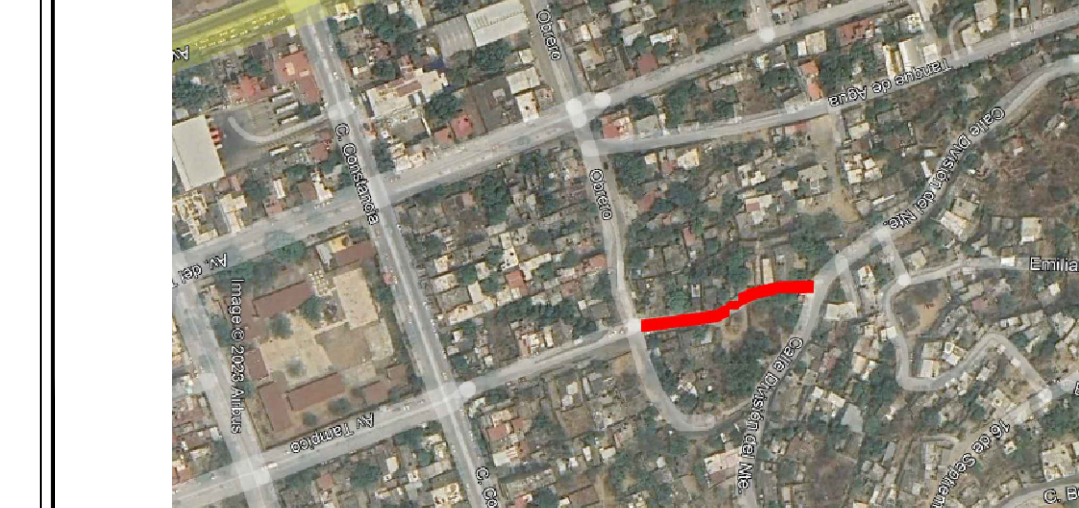

H. AYUNTAMIENTO DE SALINA CRUZ, OAXACA
"EN UNIDAD AVANZAMOS"

PROYECTO: CONSTRUCCIÓN DE LA PAVIMENTACIÓN CON CONCRETO HIDRÁULICO EN LA CALLE PROLONGACIÓN TAMPICO ENTRE LA CALLE OBRERO Y DIVISIÓN DEL NORTE. BARRIO ESPINAL.

PRESIDENTE MUNICIPAL: **C. DANIEL MENDEZ SOSA**

REGIDORA DE OBRA: **ARQ. ADELA MORENO MENDOZA**

DIRECTOR DE OBRAS: **ING. GUSTAVO DOMINGUEZ MORALES**

D.R.O MUNICIPAL: **ARQ. ANTONIO VENTURA LAGUNAS**

PROYECTISTA: **ING. ANDRÉS CRUZ LARA**

PLANO: **PLANO DE PERFIL Y SECCIONES TOPOGRAFICAS**

ESCALA: 1:100
 ACOTACION: METROS
 FECHA: JUNIO DEL 2023

CLAVE: **A3**